



A division of CRADLEY MOTOR WORKS Ltd. Haven Works,  
St. Leonards-on-Sea, East Sussex. England TN38 8BG

TELEPHONE: 01424-717000 – EMAIL [sales@sportsandleisurecars.co.uk](mailto:sales@sportsandleisurecars.co.uk)

## **ASSEMBLY INSTRUCTIONS**

**for**

### **MODELS 223 – 224**

based on 2CV – Dyane 6 – Ami8

## **INTRODUCTION**

You are contemplating the creative possibilities open to all car manufacturers, large and small, to assemble a unique product.

LOMAX conversion kits combined with the engineering genius, which originates from Le Patron of 2CV, Dyane and Ami, offer the scope for personal satisfaction that would be difficult to surpass without considerable financial resources.

LOMAX remains inexpensive, even if development is carried to the farthest limits of its considerable potential.

You decide how far you wish to go in matters concerning standards of fitting, build quality, innovation and excellence.

Therefore, LOMAX has been economical with written explanations, which may confuse or complicate an otherwise straight forward project. The emphasis is upon the avoidance of pitfalls and reminders of the obvious, which may give rise to a set back in your plans.

The name of the game is enjoyment. To this end LOMAX are always available to advise, guide and correct you, or recommend a better solution, if difficulties arise.

It is possible to construct LOMAX within a time scale of 45 - 50 hours if you are an experienced mechanic or fitter. Less experienced persons should not attempt to equal this; a little more time is of great value, particularly when you are enjoying what you are doing.

Assembly of a kit car is not quite like making a model from pre-formed components, when only the things that show, are of importance.

The things that do not show are in reality those which should command equal attention. The final result can be only as good as the preparation will allow.

LOMAX was truly inspired by the genius of Le Patron, and this should never be degraded by poor work.

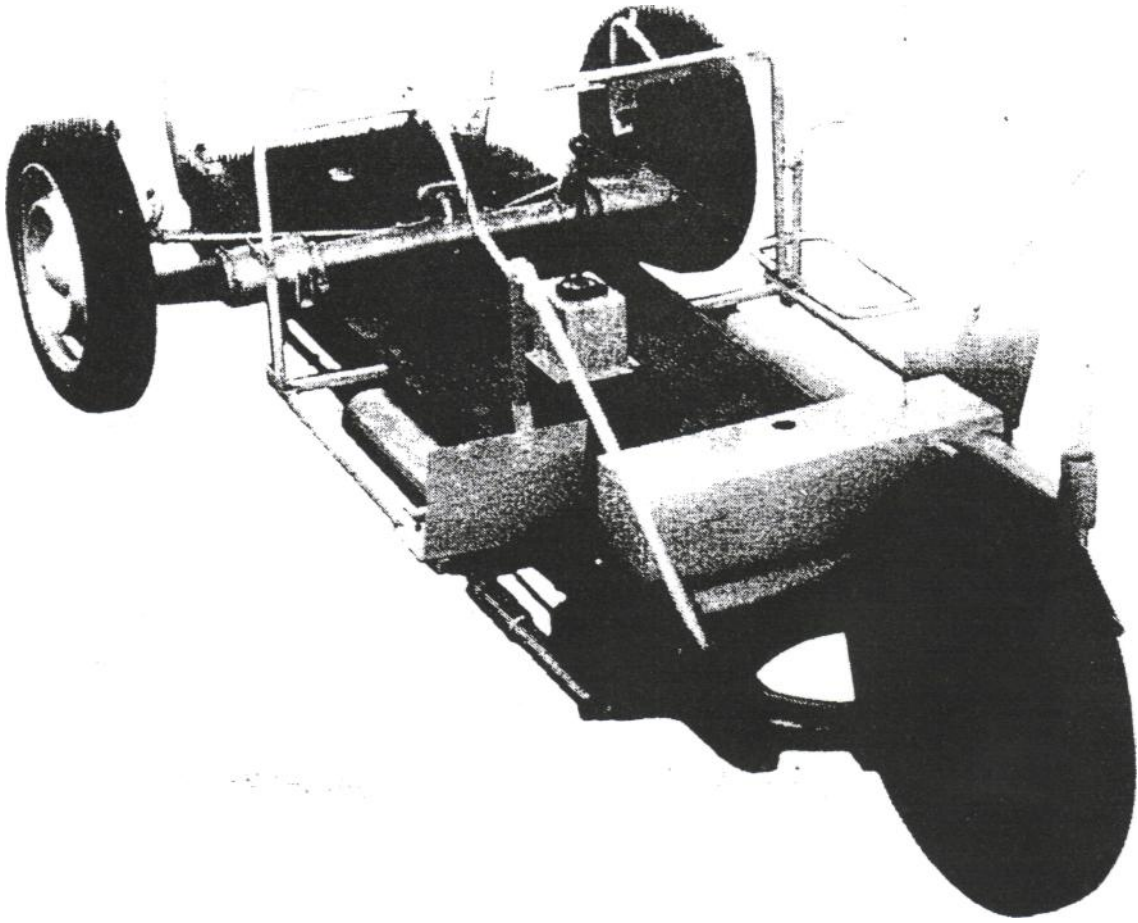

Your LOMAX Kit has been professionally designed and therefore a normal set of tools and a metric socket set are all that is needed to produce a LOMAX car from the various components.

Using the brackets and accessories available from LOMAX means that there is no need for any welding.

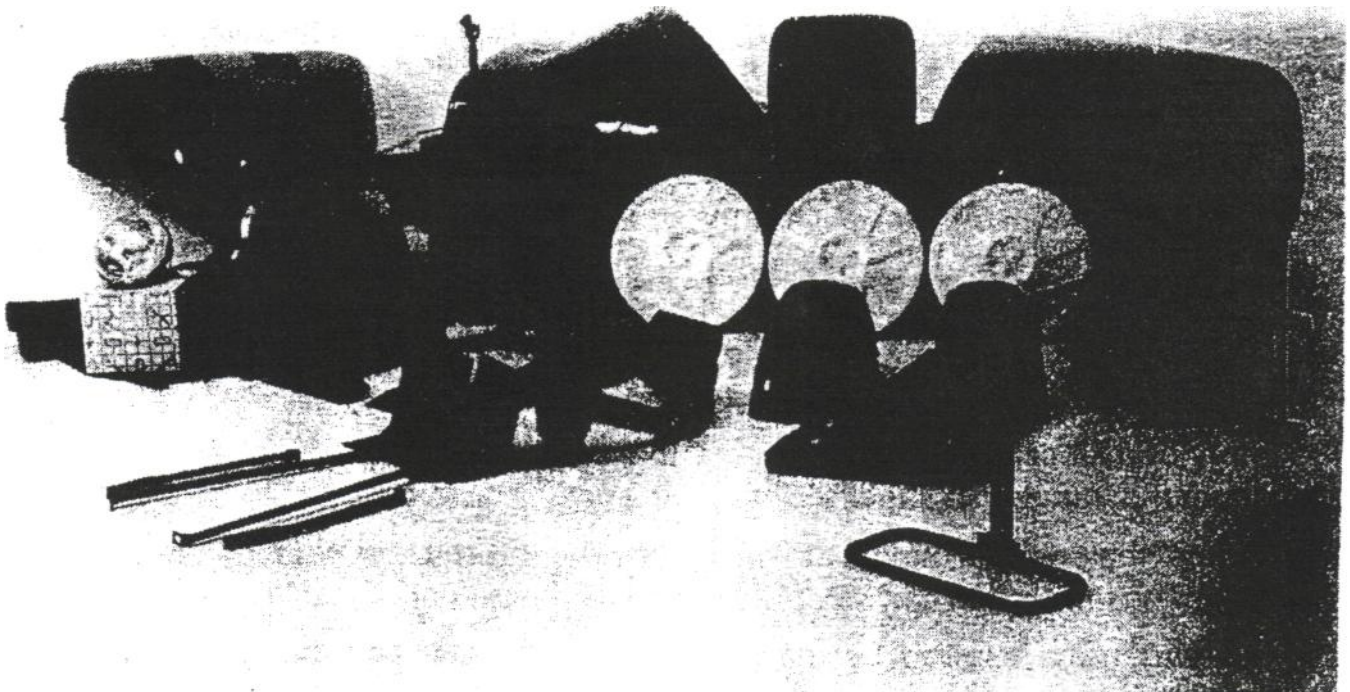

## GENERAL INFORMATION

Obtain Haynes or Autodata Manual relevant to the chosen donor vehicle.

It is essential to replace all brake pipes.

Ensure that all the mechanical work has been completed on the chassis. Areas that require particular attention are as follows:-

**KING PINS:** Jack up the car and check for movement - only a small amount is allowed for the M.O.T. If the items require reconditioning, it is a simple exercise, following the instructions in the manual. If however it is beyond your capabilities, remove the complete arm and take it to your local 2CV Specialist, who will be pleased to service the item for you.

**SUSPENSION:** Very little can go wrong with this simple yet effective system. Check the shock absorbers by pushing down on the chassis, then release -- the car should rise back to its unladen position and should not bounce up and down. Check, the springing - it should be quite difficult to press the chassis up and down using one foot. If it is easy, there is a chance that the suspension units need replacing. Also check for any sideways movement of the suspension arms. If movement is detected it can be rectified by tightening the very large castellated nut which secures the arms. Follow the procedure in the manual

**ALTERNATOR:** A reconditioned Alternator is always a sound investment, this component will probably be worn to the extent that a breakdown may be likely.

**ENGINE:** The two-cylinder engine has been found to be extremely reliable and engines with 80 or 90,000 miles 'under their belt' are capable of providing many more miles of trouble free motoring. It is recommended that the two front engine mountings and the gearbox mounting be replaced. It is also good practise to de-carbonise the older engine, following the procedure described in the manual. The oil cooler should be steam cleaned. Replace contact breaker points, plugs and condenser as a matter of course.

## PREPARATION OF CHASSIS

### REMOVAL AND FITTING OF REAR ARMS.

Refer to manual for removal procedure if difficulty is experienced with the following. Remove plastic end caps and unscrew brake pipe connections. Remove split pins in large castellated nut, holding the bearing in position. Tap the castellated nut around in an anti-clockwise direction using a drift. When the nut has been removed the arms can be removed by tapping outwards.

### WHEN FITTING THE MODIFIED ARM.

**Make sure that the bearings are in good condition, i.e., Free from shake or pitting. They should be clean and well greased. Replace and tighten the large collar to 30 – 40 kgf/m, then the min extra to the next splitpin slot. Over-tightening can cause damage to bearings.**

## WORKING ON THE BODY.

Reinforced plastics are relatively easy to work with and by using ordinary hand tools, all the necessary work can easily and professionally be carried out. A dust mask should be worn when sanding and drilling.

It is good practice, when cutting or drilling through the body, to place masking tape over the area and mark out on the top of the tape.

When drilling G.R.P. do not use a very sharp drill, as it will tend to break through.

Take off all sharp edges with a hand file or abrasive paper.

Removing the flash lines from the body, is simply accomplished by masking out both sides of the flash line with tape and then rubbing the area with wet and dry (grade 400 grit). When the flash has been smoothed away, remove the tape and finish off with grade 1000 grit. This procedure can be used to remove any slight blemishes or scratches.

The high gloss finish can be restored by using 'T-Cut' on a polishing mop powered by an electric drill.

Blind fixing to G.R.P. can be achieved by using "ARALDITE EPOXY" on a freshly abraded surface. Allow 24 hours for complete curing to take place.

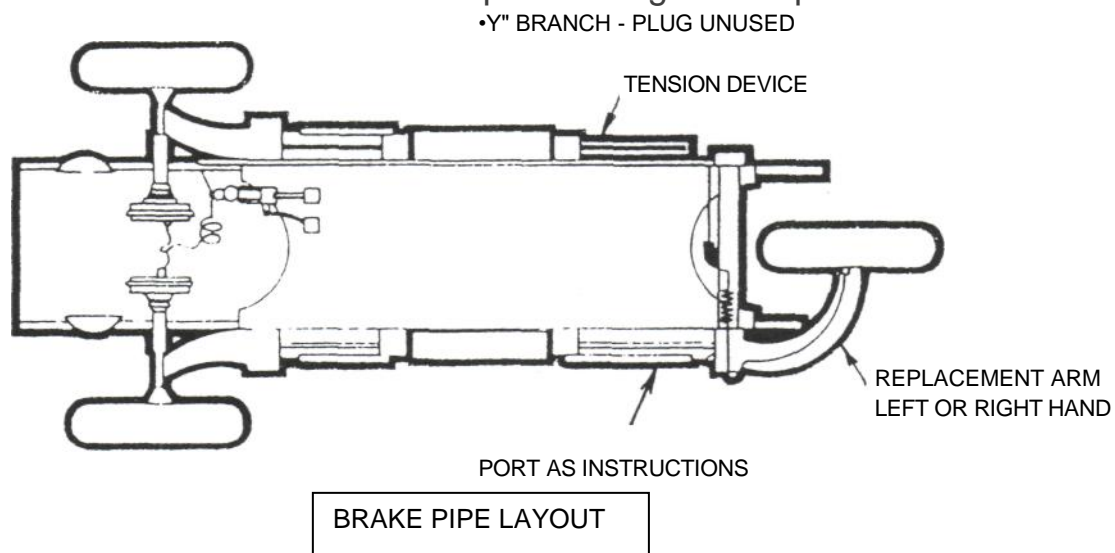

**IMPORTANT: REPLACE ALL BRAKE PIPES & SERVICE ALL BRAKE ASSEMBLIES**

It is essential to fit a new brake pipe coil - these are not expensive and are well worth the small cost to ensure total safety. The new brake pipe is fitted following the same route as the old one. However, it needs to be straightened at the back plate end and securely fixed to the suspension arm. The redundant hole on the brake pipe 'Y' piece can be closed using an 8mm bolt with PTFE tape, to ensure that a good seal is obtained. Finally tighten firmly.

To avoid fatigue in brake pipes, all should be firm. Fasten securely with cable clips, pop riveted into position. Alternatively, cable ties may be used.

Bolt the new rear seat belt cage mount to the chassis using the holes left by the original rear seat belt mount. Refer to photograph of complete chassis to aid fixing. Do not tighten the bolts completely - some movement should be allowed.

# BUILD UP INSTRUCTIONS FOR THE LOMAX 223 and 224.

With the chassis prepared, painted and reconditioned as required -

Remove the rear seat belt mounting cross member (if fitted) from the rear of the chassis (above the fuel tank) (223 Model only).

Remove the fuel tank (223 Model only).

Remove inertia dampers from the front of the leading arms (if fitted).

Fit the lengthened suspension eye bolt. (Exchange item).

Using a workshop manual for guidance fit the modified trailing arm and rest it on the rear chassis member. This modified trailing arm can be fitted to either side, i.e. Left or Right (this information is for 223 Models only) and dependant upon supply.

Trim-the chassis member so that the modified trailing arm will have clearance, then cut off the opposite side approximately 10mm past the furthest hole used for the rear seat belt anchorage frame (223 Models only).

Fit LOMAX petrol tank. This is fitted in the position shown in the sketch and is bolted to the chassis, using tags provided. It is very important to fit the tank breather pipe provided (223 Models only). Use the original donor tank sender unit, but fit a new gasket.

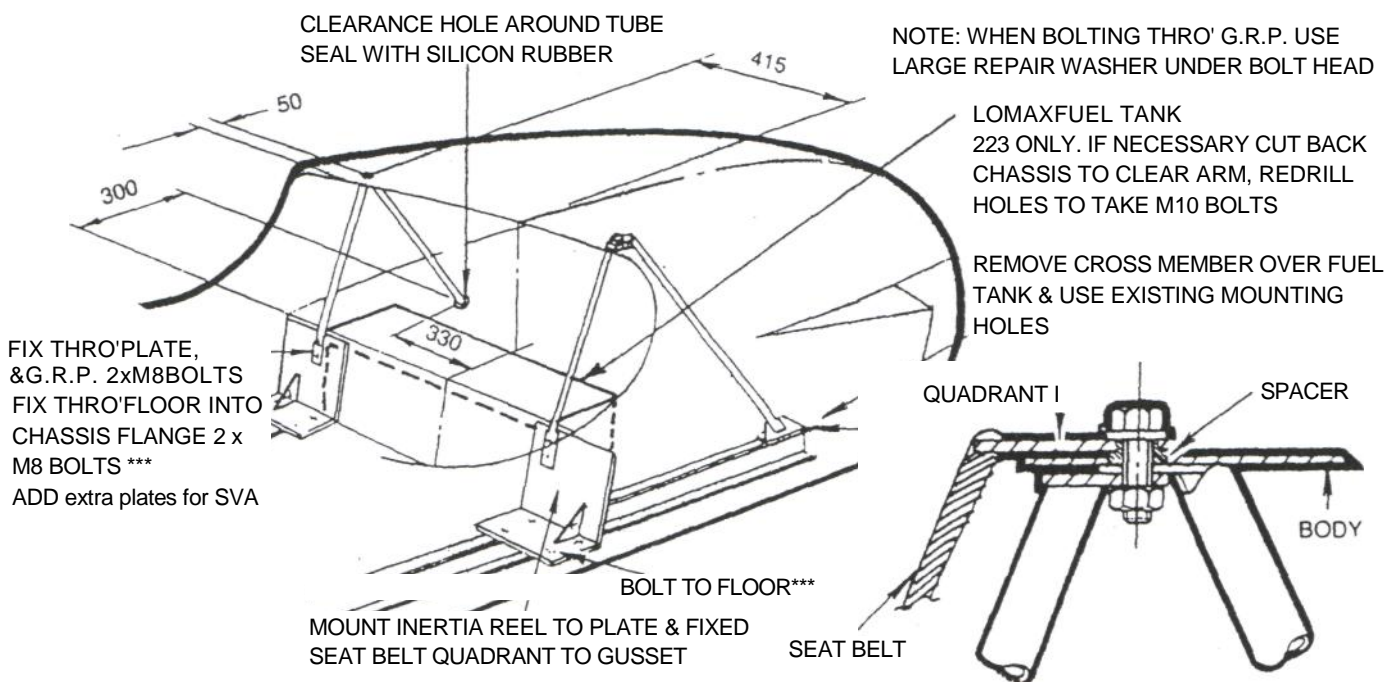

This page is attributable to old completed and registered kits only.

The dummy rear arm of the 223 should be utilized either via Lomax rear anti-roll / interlink bar or other device.

NON-UTILISED REAR SPRING MODIFICATION

Tension the off side suspension spring by sliding the tube over the tie rod and by screwing in the eyebolt, compress the spring (refer to diagram).

Cut the front bulkhead to allow the floor to rest upon the chassis.

Cut out the rear floor to give clearance around the rear wheel (223 Model only).

Cut two 2" diameter holes in the rear bulkhead floor, to allow the seat belt frame to pass through, also cut the hole to accommodate the rear wheel. Trim the fibreglass at front, level with the floor to a width of approx. 34". This will allow the body to fit on to the Citroen chassis.

If the donor vehicle is an Ami, the floor will have to be cut to accommodate the larger suspension units. These cut outs can be either fibre glassed in or boxed over later.

STEERING PINION - FIT RUBBER GROMMET AGAINST BODY

FILLER CAP IMPORTANT: FIT BREATHER PIPE TO PETROL FILLER PIPE

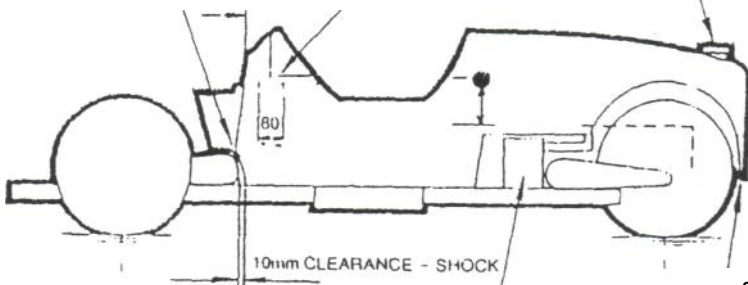

PETROL TANK HARD UP TO CROSS TUBE, FIT DONOR SENDER UNIT, REPLACE GASKET ENSURE GOOD EARTH TO TANK

223 ONLY, IF WHEEL FOULS CUT BACK BODY EDGE TO GIVE 10MM CLEARANCE

BODY TO CHASSIS DETAIL - 223

Measurements: Hood Frame and Screen Location

IMPORTANT: The measurements differ on each side of the vehicle due to built in asymmetry which is not visually apparent. This is necessary due to projected location of components on some models.

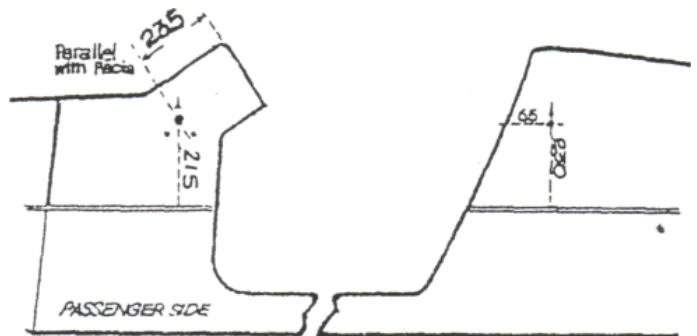
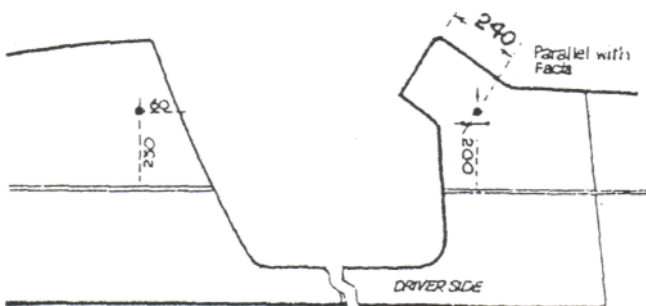

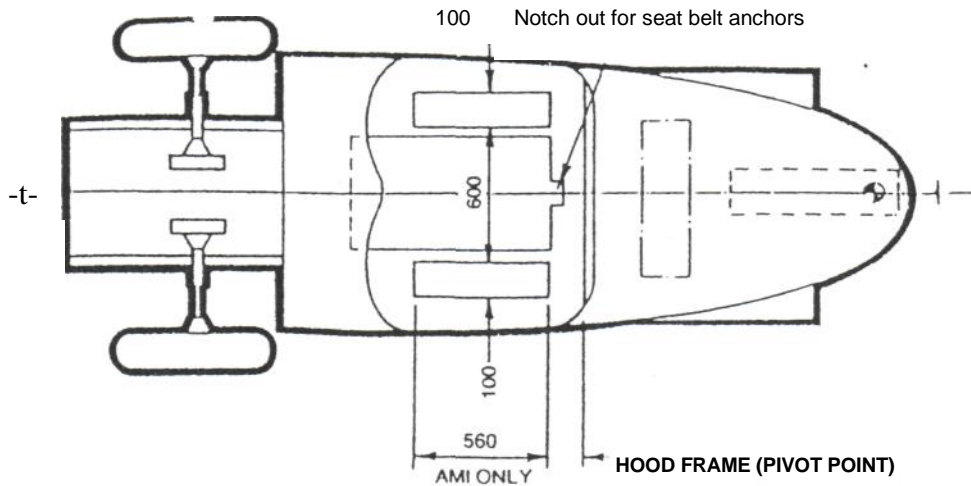

Fit the body on to the chassis and check that it fits firmly - it is advisable to replace the sponge rubber seal found on the donor vehicle to prevent leakage in wet weather.

## CENTRALISING THE BODY ON TO THE CHASSIS.

It is essential that the body fits centrally onto the chassis. To do this, mark the outside face of the rear tyre with chalk or felt tip.

Mark the rear of the body in the centre beneath the floor.

Measure the width of the car at floor level, both at the front and rear. Divide and draw a centre line on the plywood floor of the body. Mark out the centre line on the chassis. This can be taken from the middle of the seat belt floor anchorage holes and the centre of the chassis at the front end.

The body can then be placed on the chassis. Line up the rear tyre with the line on the rear of the body. The marks on the inside of the body should be aligned with the marked out centre line of the chassis.

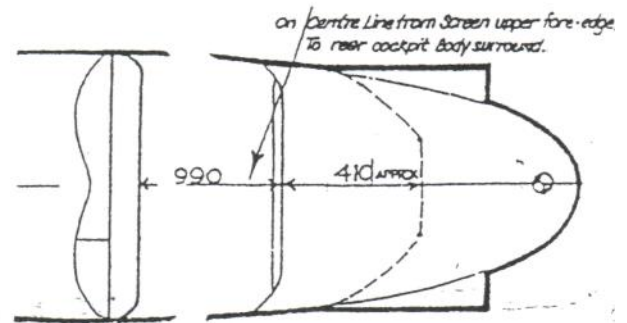

## FORE AND AFT POSITIONING OF THE BODY.

With the body resting on the floor pan and with the pinion of the steering column entering, connect the already lengthened linkage. Then fit the top steering wheel assembly to the scuttle frame and the G.R.P. bracket behind the dash board.

Bolt in place.

Align the body to its central position.

From underneath the body, mark out four holes, 2 on each side of the chassis, then drill.

Draw a line between these holes on either side and mark out the rest of the holes to line up with those on the chassis. It is advisable to put two extra holes as far forward as possible.

**Use 8mm nuts and bolts with large repair washers on the plywood surface of the floor.**

THE PEDAL ASSEMBLY can now be offered up.

If the 2CV or Dyane is the donor, it may be considered to convert to a cable throttle from the Ami or Ami Super. The master cylinders must be changed if the brake fluids are different.

The major consideration in fitting the pedals is the distance of the throttle pedal to the side of the body. When this position has been determined to your satisfaction, drill and file clearance in the bulkhead to accommodate the brake master cylinder. Slide the unit through and bolt up. Now refit the brake fluid reservoir.

If you wish to retain the Dyane or 2CV pedal assembly you will need an adaptor bracket (obtainable from LOMAX). On disc brake models, green fluid is required and all rubber seals should also be identified with green markings. **UNIVERSAL BRAKE FLUID MUST NOT BE USED.**

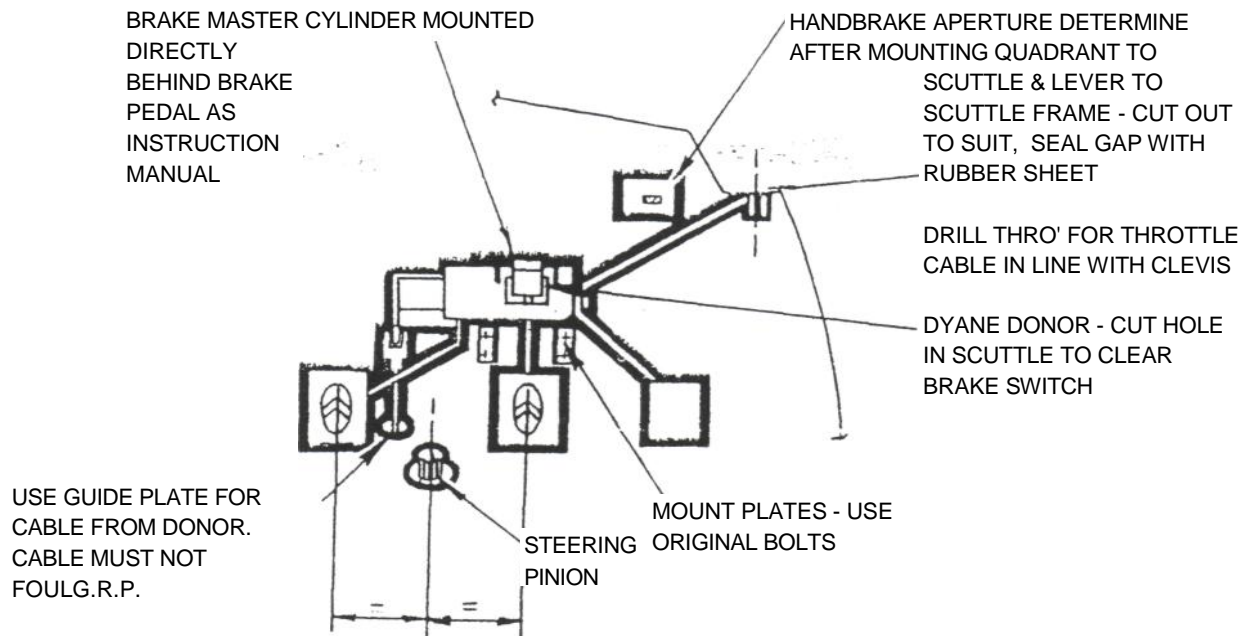

NOTES

- 1 PEDAL AREA OF FOOTWELL.
- 2 DYANE OR 2CV DONOR - MOUNT MASTER CYLINDER TO LOMAX PEDAL CONVERSION KIT & MOUNT AS AMI AMI DONOR - MOUNT PEDAL ASSEMBLY INTO
- 3 PRIOR TO ASSEMBLY - CHECK & SERVICE MASTER CYLINDER - CHECK CORRECT OPERATION OF BRAKE LIGHT SWITCH
- 4 USE LARGE REPAIR WASHERS WHEN BOLTING THRO' G.R.P.

TYPICAL FOOT PEDAL ASSEMBLY

**BOLT THE BODY TUB IN PLACE.**

Use can be made of the original bolts supplemented with repair washers in contact with the GRP body floor.

Refit and adjust clutch cable; do not overlook the spacer bolted to the outside of the bulkhead, which should have been removed from the donor vehicle.

Fit brake pipes and bleed the brakes using the standard procedure for this operation.



## STEERING COLOUMN & SCUTTLE FRAME ASSEMBLY

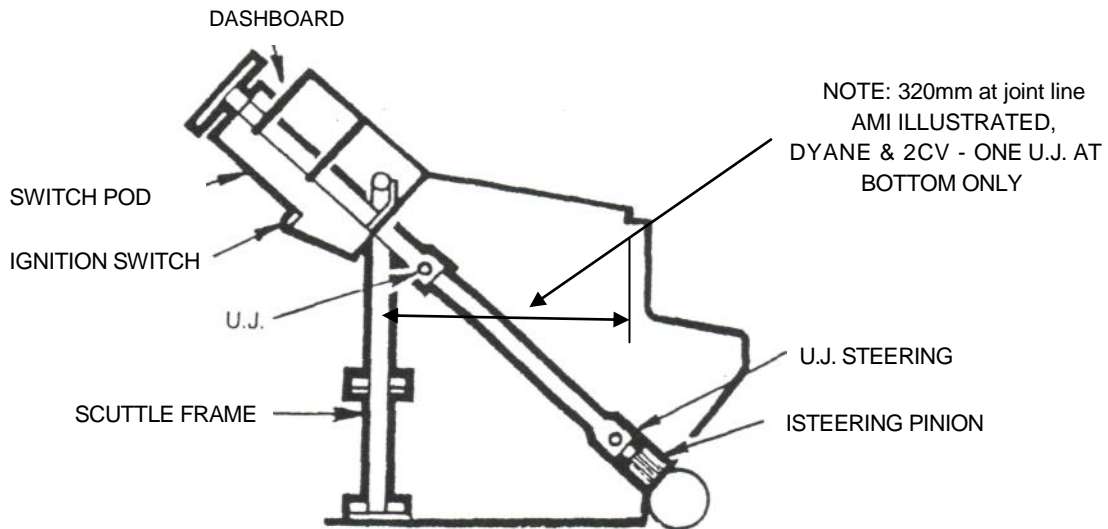

### STEERING.

The Ami steering column will fit on to the brackets provided on the body after only minor trimming and should be bolted up at the desired angle. Dyane or 2CV units can be used in modified form.

When satisfied with the position, remove, then offer up the scuttle frame between the two mounting points. Fit the scuttle frame square on to the chassis and vertically bolt to the floor.

Clamp up steering column and drill the plate on the scuttle frame. Fit lengthened universal joint, column and wheel, then bolt up using new fibre or nylon insert type lock nuts.

If the original dashboard gear change is to be used, fit to the scuttle frame. The lever will need to be extended by approx 15".

### HAND BRAKE....DISK TYPE.

Decide on the position of the handbrake lever, then bolt the ratchet accordingly to the scuttle frame in the central position, when using Dyane and 2CV donor vehicles. Use the bracket provided on the offside when the donor is an Ami.

Assemble the handbrake pivot bracket with the brake cable fitted.

Extend the handbrake lever through the bulkhead (as on the 2CV and Dyane). When you are satisfied everything is working efficiently, tighten all bolts.

### HANDBRAKE....DRUM TYPE.

Clamp the ratchet to the scuttle frame, then extend the handbrake lever to connect with the original unit. Test and bolt up.

Fit the battery in the battery box and clamp securely with the original bar from the donor vehicle.

Mark out where the steering pinion shaft touches the body, slide the body back and drill a 25mm hole for clearance around the pinion-shaft. Where the pinion shaft touches the body, remember that it is the top of the hole, which is important, not the centre. When carrying out this operation ensure that the body is central on the chassis from front to rear.

With the body resting on the chassis, centralise it by measuring from the side of the chassis to the outside of the body tub. Measurements should be done from a number of points to ensure accuracy. (Refer to separate instructions on centralising the body contained within this manual).

The body should be placed as far forward as is possible, without the rear wheel touching the body at any point. There should be a gap of approx. 10 - 15mm between the body and the front swinging arm cover plate. If the body is in contact with the rear wheel at any point, trim away the minimum amount of material from the body to allow clearance.

#### FRONT MUDGUARDS.

The front mudguard brackets utilise the inertia damper mounting points. Inaccuracy in the brackets may result in the need to pack or file smooth to ensure accurate alignment. With the car on the ground and the ride height adjusted to 150mm -200mm ground clearance front and back, from the underside of the chassis, fit the brackets and offer up the wings. These should be fairly low at the rear (approx 100mm ground clearance) to prevent spray when driving in wet conditions. Bolt up using spring washers.

On donor cars without inertia damper mounting LOMAX manufacture a special moulding stay which facilitates the fitting of wings. This item fixes on to the two bolts holding the steering drag links in position. It is important that these bolts are tightened as instructed in the manual. Alternatively, flared wings may be fitted.

Lomax recommends the use of GS instrumentation, i.e., tachometer, speedometer, battery and fuel gauges. For ease of fitting, a suggestion, is to fit a wooden, aluminium or stainless steel dashboard over the switches. The dials can be mounted to this, which is then bolted to the bulkhead.

If a floor type gear change is to be used, utilising the gear selector from the Ami Super or GS, cut sufficient from the bulkhead to allow the new gear selector shaft to enter from inside the car. With the gear box set in neutral, fit the new selector shaft. Bolt the selector unit to the floor and by selecting each gear in turn, cut the clearances required from the bulkhead. Fit a rubber boot over the hole to finish.

If a spare wheel-carrier is fitted, drill through the body - use spacers between the scuttle frame and the body as required. Then bolt in place.

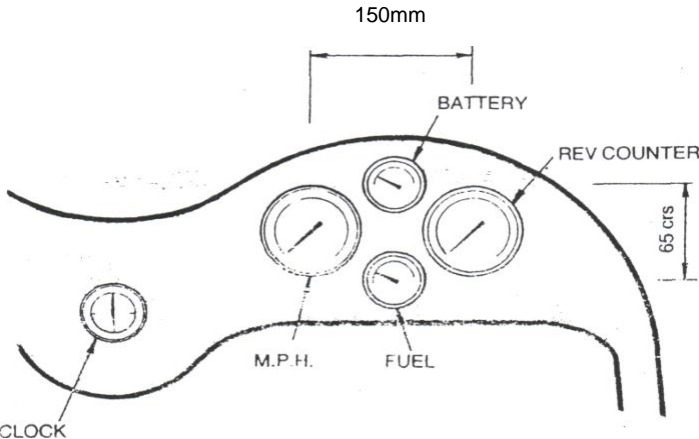

Suggested Dashboard Layout

Hole sizes  
 Small gauges – 51mm  
 Large gauges – 80mm

Scuttle Frame Assembly

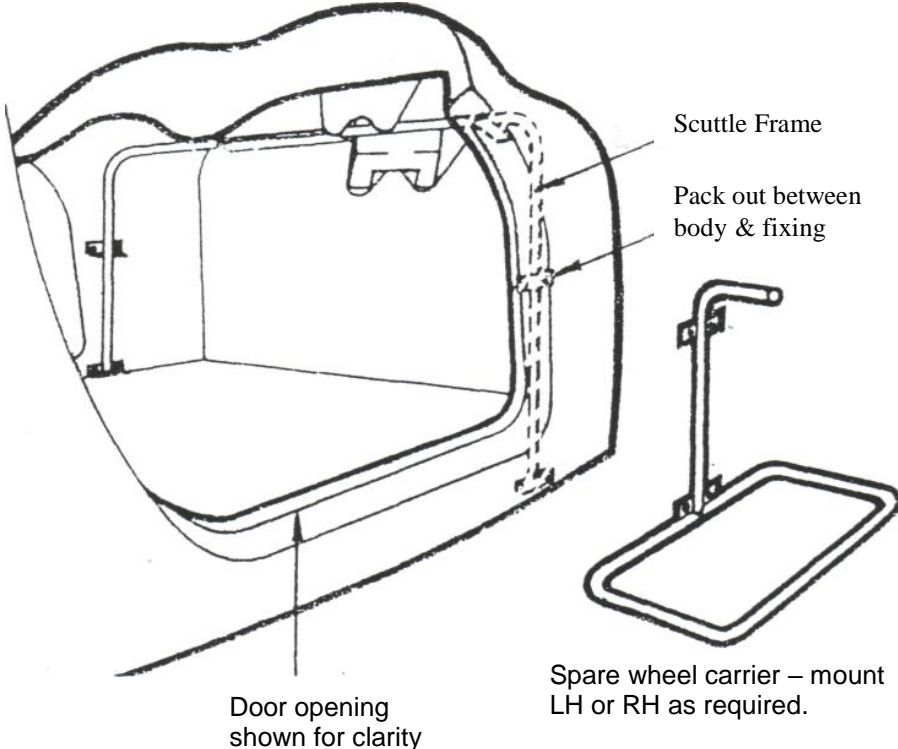

# WIRING.

If use of the original instruments is contemplated, the original wiring loom can also be used and the only modification that is necessary is to lengthen the leads, which are to connect with the headlights and indicators. -

Using GS instruments produces more of a period effect within the car. All of the instruments are used: these consist of - speedo, rev counter, voltmeter, petrol gauge and clock. All of these instruments are wired to the multi socket, from the back of the combined voltmeter and fuel gauge from the original wiring loom. The best method to ensure that complications are kept to a minimum, is to separate the loom on the back of the GS instrument panel, leaving the wires connected to each instrument separately for as long a period of time as possible. The connections are as shown on the diagram. Use only auto electrical connecting blocks and terminals. Ensure an adequate earthing system is established. The body panels and brackets are not suitable for use as an electrical earth.

## View from Rear

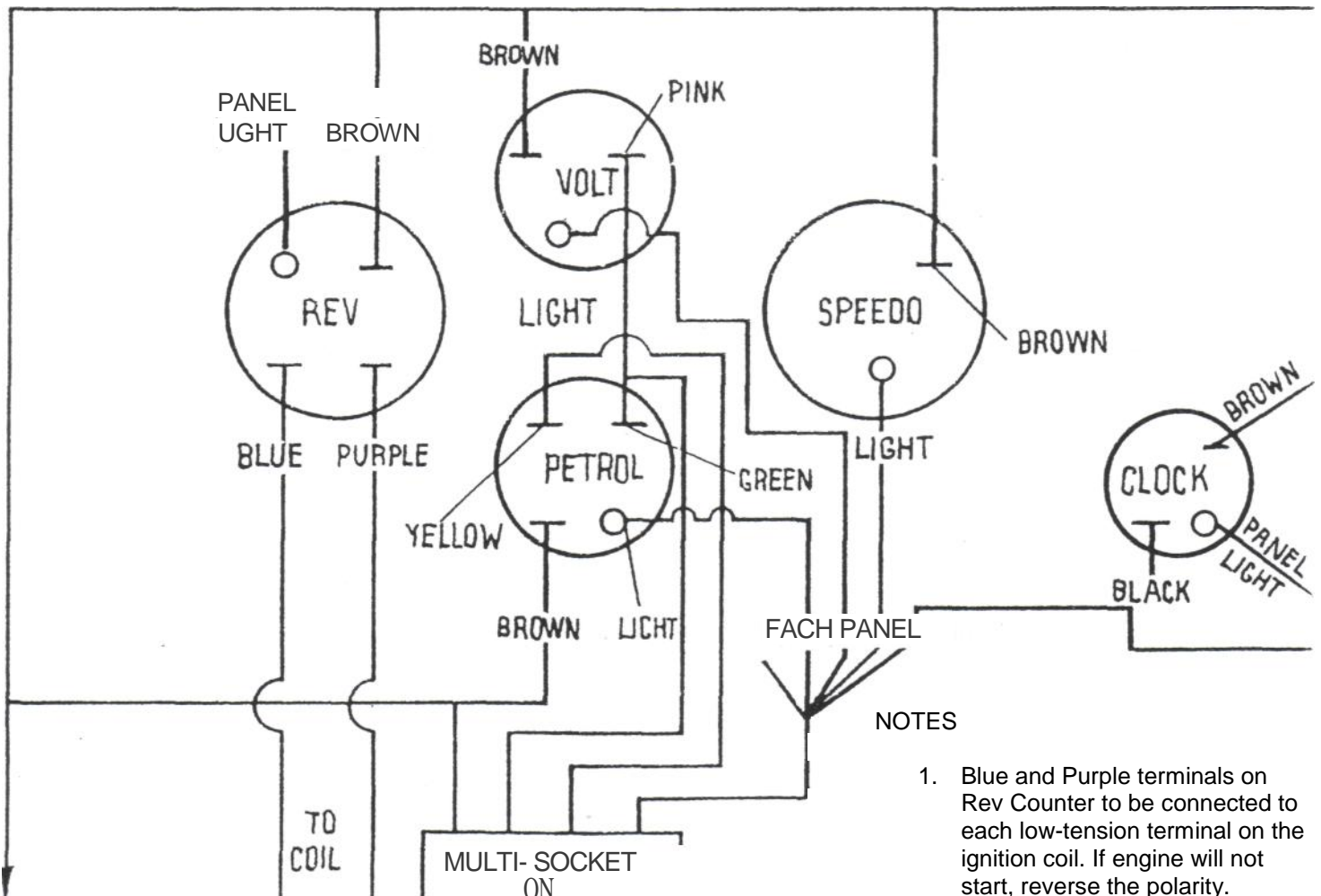

### NOTES

1. Blue and Purple terminals on Rev Counter to be connected to each low-tension terminal on the ignition coil. If engine will not start, reverse the polarity.
2. Instrument Light Bulb Holder, wire to center terminal.
3. On some models the internal indicator warning light is absent. You must fit one.

TO SIDELIGHT SWITCH-  
RED TERMINAL

TO COIL

MULTI-SOCKET ON ORIGINAL LOOM" 2.CV-0VANE-AMI

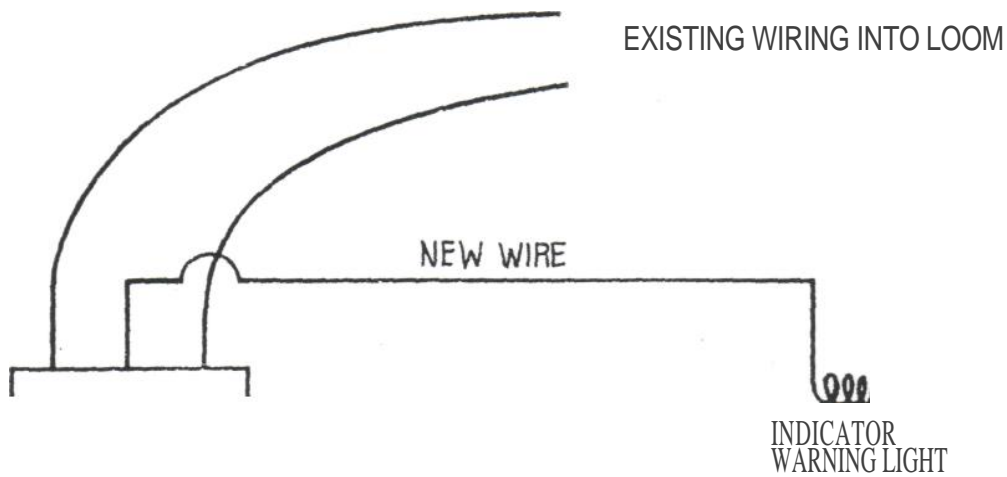

FLASHER  
UNIT

*An additional cable must be connected to the Centre terminal of the Flasher Unit. The bulb should be connected, in series, as diagram to earth.*

## *Indicator Warning Light. Wiring.*

### **WIRING.**

Utilising the original loom, mount the fuse boxes on to the outside of the front offside bulkhead. The wiring to the front lamps may need to be extended. Otherwise reconnect as original. Care should be taken to ensure that the loom is not draped over hot or moving parts.

Fit the horn. This will require a separate earth.

Fit and connect the rear lights. Although the Dyane rear lights will fit, LOMAX recommends the use of circular (Land Rover type) lights. Provision of a separate earth must be made for the rear lights.

**TO ADJUST THE STEERING LOCK.** If cycle type wings are fitted at the front, the steering will need to be adjusted and an adjuster screw will be found behind and below the kingpin. Set both sides so that the mudguards clear the anti-roll bar and exhaust and allow approx. 10mm clearance to compensate for vibration of the wings.

**TO FIT THE HEADLIGHT MOUNTING FRAME,** remove by cutting just enough of the drip tray (on the outside of the chassis member) to enable you to slide the headlamp bracket over the chassis and bring up to be level with the centre of the nearside cylinder head. Clamp up to the chassis outside lip with the clamps provided in your kit.

## FIT THE HEADLIGHTS

Headlights can be mounted to the fitted frame. Motorcycle front indicators will then fit on to the lugs beneath the headlights.

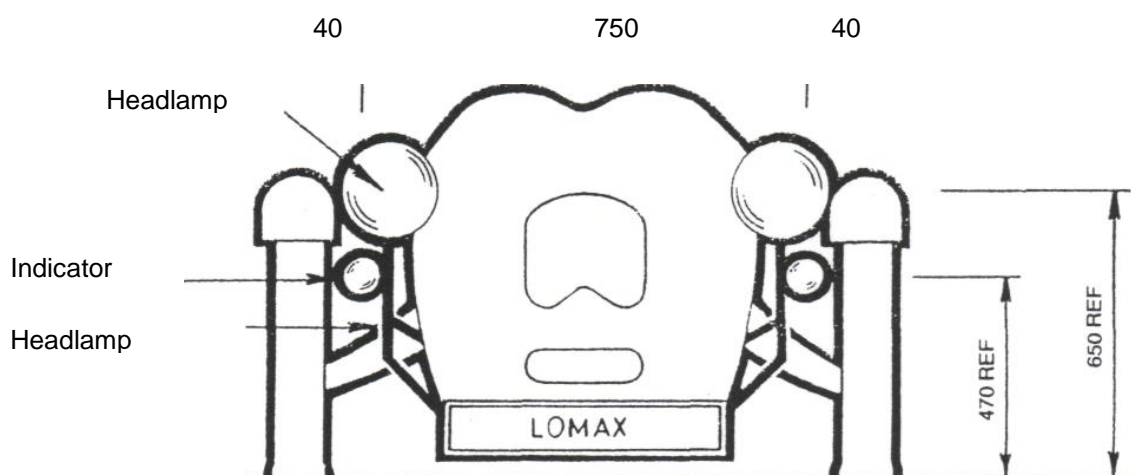

RECOMMENDED LIGHTING INSTALLATION

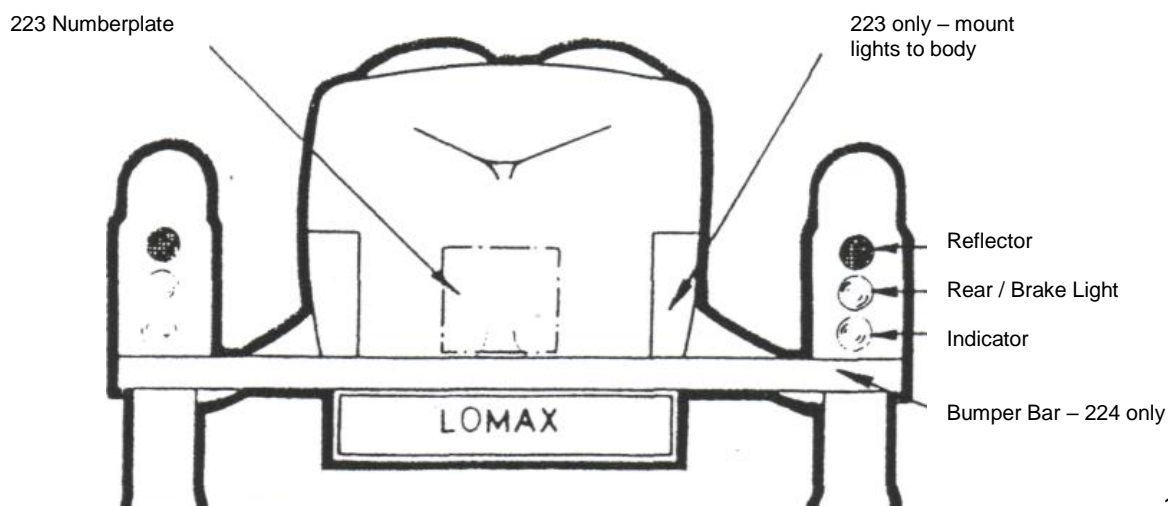

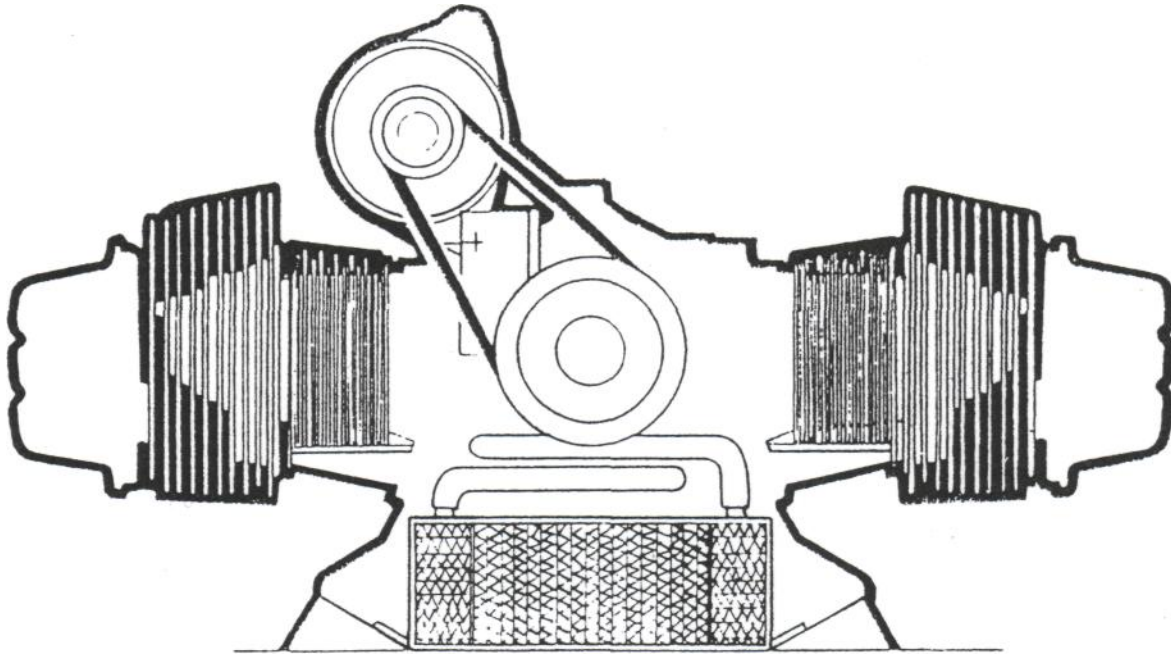

RE-SITE ALTERNATOR, OIL COOLER & COIL USING LOMAX BRACKETRY

## ENGINE COMPARTMENT LAYOUT

### ENGINE.

With the cooling ducting, oil cooler, alternator, inlet/exhaust manifold, fan pulley (which has already been reduced in size) and oil filter removed, fit oil cooler bracket to inner two of the four engine mounting bolts with the 'T tube facing forward. To fit, slacken all the engine mounting bolts including the four holding the crankcase. Fit bracket and re-tighten. Check everything for final tightness. Hang the oil cooler from the bracket and fasten, using the original nut and bolt.

Fitting the oil hose should be done dry to ensure a good tight fit on the pipes. Cross the hoses over and clamp tightly with 'Jubilee' clips, ensuring that the hose does not foul the starter dog. Lomax offer a more durable braided hose upgrade.

### ALTERNATOR MOUNTING BRACKET

A new one piece bracket has been introduced for easy assembly, and improved adjustment.

It is fixed in position by bolting through the oil cooler mounting hole. An 8mm high tensile-bolt should be utilised. The alternator lug fits in between two metal projections, and allows adjustment by means of the 8mm bolt on the top of the bracket. Once the correct belt tension has been arrived at, the lock nut should be tightened.

Fit the modified oil filler, the drain tube may need to be trimmed to ensure a free run back to the dip stick.

## EXHAUST SYSTEM.

The re-location of the alternator means that the right hand 'Hot-Spot' pipe is in the way. There are several courses of action.

LOMAX can either supply a modification to your original exhaust, by removing both 'hot-spot' tubes or one side only. If the pipes require chroming, the last mod. is required for a neater appearance. Front tubes are also brazed to the manifold. This modified unit is bolted into position using the original mounting points. Use new exhaust clips, together with 'fire gum'. The expansion box beneath the gear box is used in its standard form. If cycle wings are used, a modification to the section of the exhaust pipe from the expansion box to the silencer is required. This is in order to clear the cycle wings when on full lock. The standard silencer is used and looks effective when painted with good quality manifold paint.

LOMAX custom built high performance 2-1 exhaust systems are also available.

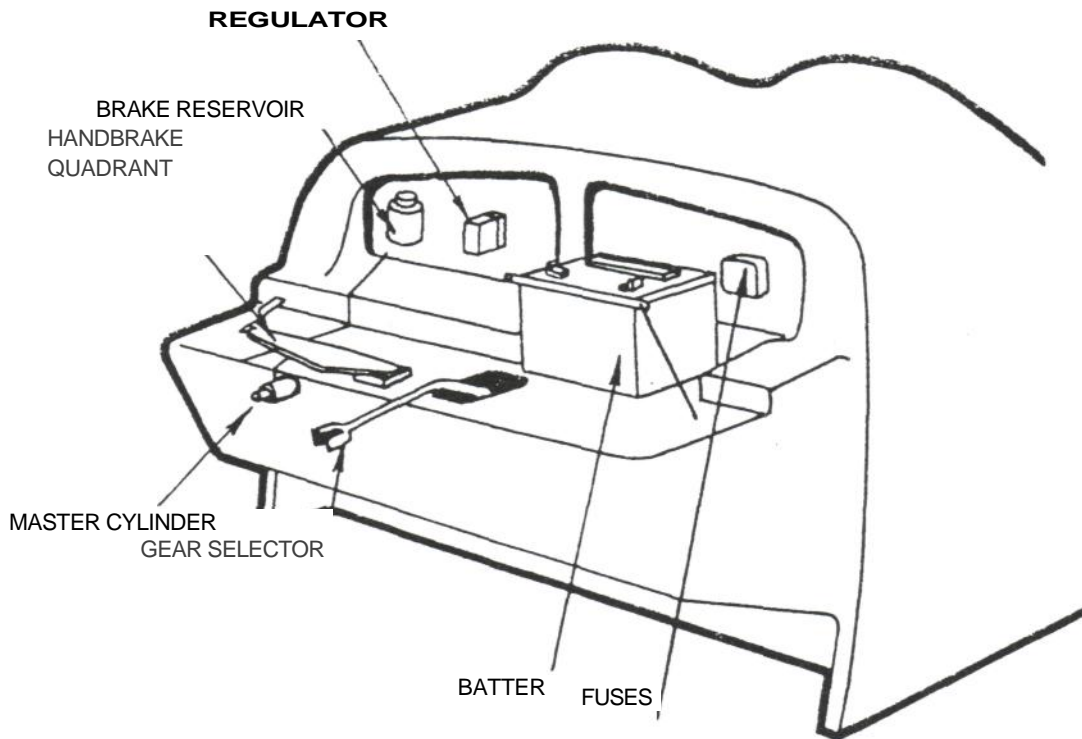

*Typical Under bonnet components*



## **SEATING.**

If LOMAX seating is not used, the recommendations are as follows: MG Midget, or Triumph Spitfire. The major consideration being, the relative height from the seat squab to the chassis. Also bear in mind that the tonneau will have to fit over the top of the seats.

Fit the front seat belt cage, then drill through the upper body, bolt in place the upper seat belt with its mounting. Then fit the remaining parts of the seat belt as originally designed refer to diagram.

Trim and bolt the engine side panels to the drip tray. Trim the bonnet as required, allowing clearance around the exhaust, ensuring the horizontal return under the grill is level with the top of the chassis.

N.B. The towing loops will have to be removed from the front of the chassis and the front corners of the chassis must be trimmed to suit. Hold the bonnet in place with clips as required.

Fit the grill by bolting in place to clear the opening for the starter handle. Finish the edges with body filler.

Fit the original exhaust (without the tailpipe by fixing the rear expansion chamber to the side of the body at approximately floor height, using 'cotton reels', i.e. spacers available from most motorist accessory shops.

Fit the rear wheel cover. Seal with mastic or other waterproof compound of choice.

## **PETROL CAP.**

Although the original system can be used, LOMAX recommends the use of a Triumph Spitfire type flip top filler and flexible filler hose. Fit the petrol cap and filler hose as required. The breather pipe is of vital importance - check that this detail has not been overlooked. The hose **MUST** be of the petrol resistant type.

Fit carpeting, rubber mats and sound proofing as required.

Fit aero screens. Care should be taken to line up both screens at the same time to ensure accuracy.

Fit rear view mirror as required.

Fit rear number mounting and plate.

Test all wiring and run engine.

When fitting the Tonneau, begin from the centre and work outwards. If this is done in cold conditions, remember to stretch the tonneau before drilling each stud, as the material will 'ease' considerably when warm.

When you are satisfied that the car is finished, check over every item again, making sure that each part is secure.

M.O.T. and SVA

The car will have to be weighed for the licensing authorities - in the case of 223 Models, the weight of the car has to be below 450kg to comply with regulations. .

**Tax, insure and DRIVE IT !**

# DONOR VEHICLE INSTRUCTIONS

## GUIDE NOTES FOR THE PREPARATION OF THE DONOR VEHICLE FOR ACCEPTANCE OF THE LOMAX 224, 223 and 424 UNITS

### *STRIPPING THE DONOR CAR*

If possible, before stripping the donor car, carry out an extensive road test in order to check the brakes, steering, engine, gearbox and clutch.

If the car is a non-runner it is best to make it run prior to the many alterations which are to take place. If any area is suspect, make a note so that it may be rectified at a more convenient time. Wear is to be suspected in the front wheel bearings, the kingpins and the drive shaft splines.

It is strongly recommended that renewal of brake pipes, shoes, or pads is carried out if the vehicle is more than three years old.

A good workshop manual for the original car is a most useful asset and well worth the comparatively small investment.

For rapid removal of unwanted components, a good metric socket set and combi spanners are essential. The following items are also required: a set of screwdrivers, a hammer, penetrating oil and a hacksaw.

### *ASSEMBLIES, WHICH MAY BE REQUIRED FROM THE DONOR CAR*

Rolling chassis - complete with all suspension, engine and gearbox complete.

Steering column.

Pedal assembly

Hand brake and mounting bracket. The mounting bracket is spot welded to the body.

Seat belts and anchorage points.

Rear lights - 2CV and Dyane, plus all bulbs.

Wiring harness, instruments and switches.

N.B. If it is intended to re-use the original harness, clearly label every connection.

Wiper assembly.

The complete exhaust system.

Fuel tank and pipes.

Gear change. The floor change from the GS or Ami Super cars is easily modified if a floor change is required.

## *BODY REMOVAL*

- 1 Remove identification plates from body.
- 2 Remove rear lights completely and the bulbs from the other lights.
- 3 Remove bonnet, boot and spare wheel.
- 4 Unfasten all bolts holding wings, side panels, wheel arches and front bumper assembly and remove these items.
- 5 Disconnect and label all control cables and wiring back to the engine.
- 6 Remove seats.
- 7 Unfasten hydraulics and brake assembly and remove.
- 8 Remove steering column.
- 9 Remove petrol feed and filler pipes.
- 10 Unfasten all bolts through floor (11mm), including those in the boot.
- 11 On the Ami the rear also has bolted clamps to be removed.
- 12 Rock the car body from side to side. If it resists, then all the bolts have not been removed. If the body is not to be salvaged, or sold, it can be pushed over and off.
- 13 The rolling chassis is now ready for thorough cleaning before structural and mechanical checking and reconditioning in conjunction with the workshop manual.
- 14 Dispose of old body, after checking that you have not left anything on it that may be of use.
- 15 223 and 224. Referring to the manual, remove the engine cowling and fan.
- 16 The flange to which the fan was bolted must be cut down to approximately 5" diameter.

## GENERAL NOTES

### 1. Fitting rear internal mudwing. 223 only.

It is most important to fit the mudguard in such a way as not to touch the rear tyre when the car is fully loaded.

Cut the rear floor leaving at least 25mm (1") gap around the wheel and tyre.

With the body in its correct position, jack the Lomax 223 under the rear of the chassis. Disconnect the rear suspension tie rod, and move the arm to its highest position into the body. The mudguard can then be placed in position and the clearance checked.

Once the position has been established, bolt and fix in place with waterproof mastic.

### 2. Fold Down Windscreen (NO LONGER AVAILABLE)

It is important if the car is to be driven with the windscreen folded down, that a safety catch be fitted to prevent the windscreen moving out of position. Considerable pressure is generated under the screen in the folded down position, by the wind.

### 3. Front Mudguard Brackets now Inertia Type.

With this type of mudguard bracket, it is important to use new bolts (high tensile 7mm) from the local Citroen dealer. Originally the car has one long and one short. Both should be the long type. New tab washers must be used.

### 4. Bonnet Fixings

Many types of fixings are available for securing bonnets. Whichever type of clips or catches are used, a secondary system should be employed. In its simplest form a leather Bonnet Belt may be provided and also adds to the "Period" look of the car with the continental bonnet, which may be hinged at the back.

An ideal secondary securing position is located by the depression for the starting handle.

### 5. Wire Wheels

When fitting the Lomax Splined Hubs to the Citroen studs, secure the nuts with Locktight or "Centre Popping" the end of the nuts.

When the wire wheels are fitted onto the splines ensure that the taper on the wheel hub fits hard against the taper on the splined hubs. Ensure the spinners are fitted to the correct hub.

Check everything is still tight after the first 50 miles then again after 500 miles have been completed.